

SLOTH: Let the Hardware Do the Work!

Wanja Hofer, Daniel Lohmann, Fabian Scheler,
Wolfgang Schröder-Preikschat

**Friedrich-Alexander-Universität
Erlangen-Nürnberg**



SOSP 2009, WiP Session



Confessions of a Slothful



How It All Began...

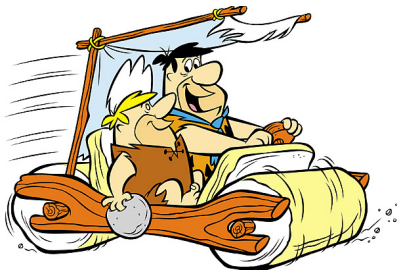

- Building embedded OSES as used in automotive industry
- Prevalent OS standard: OSEK OS
 - Event-triggered, priority-driven real-time system



Let the Hardware Do the Work!



SLOTH: Threads as Interrupts

- Idea: Let interrupt subsystem do the scheduling and dispatching work
- New: All threads are interrupt handlers and have interrupt priorities
- New: `setReady(thread)` is implemented as an IRQ



SLOTH: Design and Example

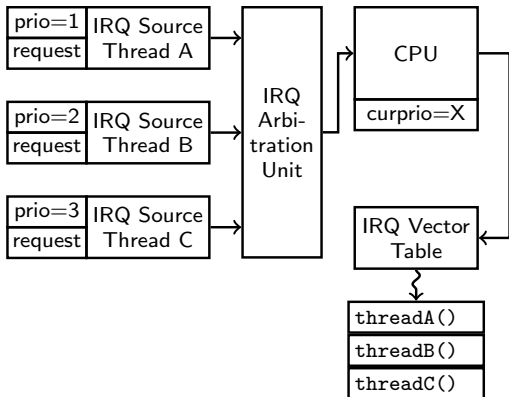

SLOTH: Design and Example

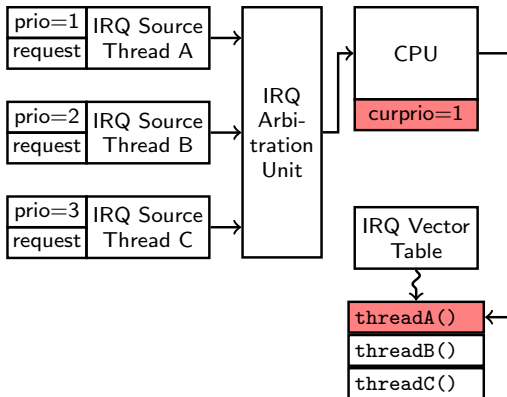

SLOTH: Design and Example

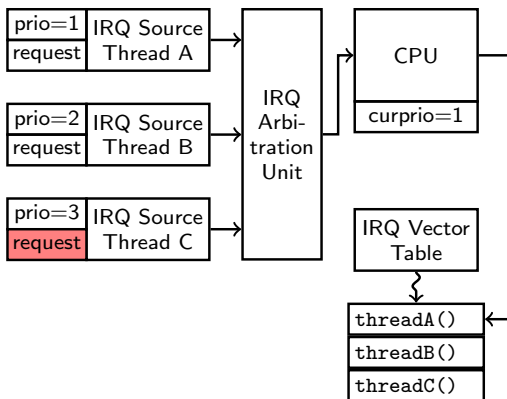

SLOTH: Design and Example

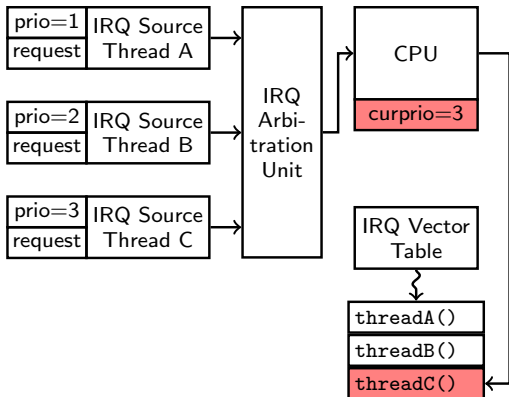

SLOTH: Design and Example

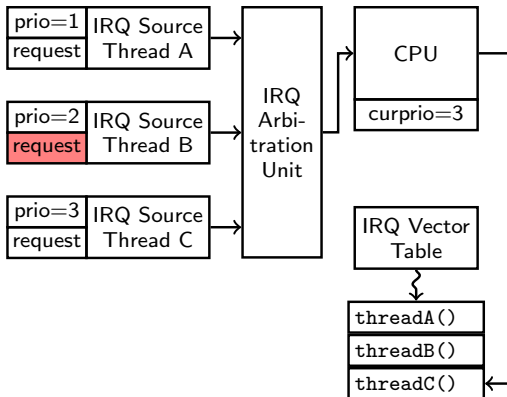

SLOTH: Design and Example

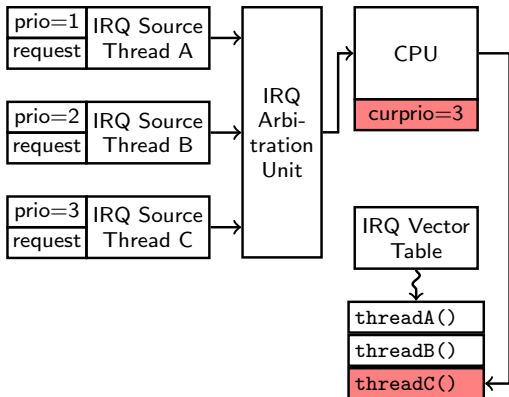

SLOTH: Design and Example

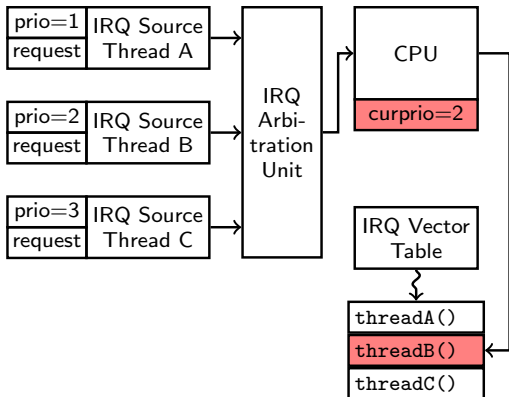

SLOTH: Design and Example

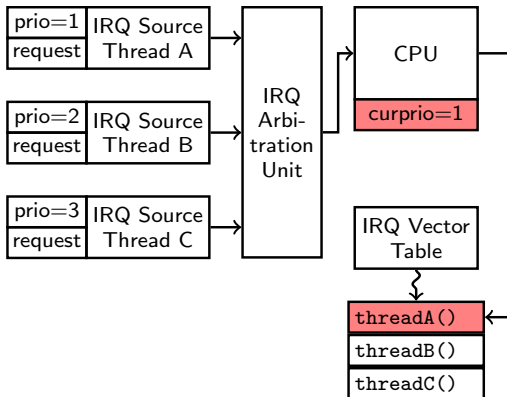

SLOTH: Advantages

- Simple
- Small
- Fast (2–20x)
- Cool



SLOTH: One of the Seven Deadly Sins



David Fincher, Se7en (1995)



SLOTH: One of the Seven Deadly Sins



David Fincher, Se7en (1995)



Nicolas le Rouge, Le Grant
Kalendrier Des Bergiers (1496)



More About Being a SLOTH

1. Talk to me!
2. <http://www4.cs.fau.de/Research/Sloth/>

